

Computational Challenges in Nuclear and Many-Body Physics

Summary

Yoram Alhassid (Yale University)



- Physical systems of interest
- Challenges in many-body physics
- Computational methods and their formulation
- Highlights of recent progress
- Some outstanding problems

Many-body physics

Systems of interest

Correlated finite-size systems: nuclei, molecules, quantum dots,
small cold atom clusters, nanostructures,...

Bulk strongly correlated systems: neutron matter, cold atom quantum gases,
electronic condensed matter systems,...

Challenges

- Strong correlations require non-perturbative methods.
- Large number of degrees of freedom and/or large dimension of spaces.
- Effective low-energy interactions: integrating out the high-energy degrees of freedom.
- Thermodynamic limit: extrapolating the finite-size results to bulk systems.

Recent progress in the field enabled by advances in computational methods and availability of high performance computational resources.

Computational methods

- Self-consistent mean-field (SCMF) theories and their extensions.
- Density functional theories (DFT).
- Quantum Monte Carlo (QMC) methods.
- Configuration-interaction (CI) shell model approach.
- Coupled-cluster (CC) methods.
- Methods based on integrable models.
- Density matrix renormalization group (DMRG) and tensor network methods.

Formulation of the computational methods

Method	Ground state (T=0)	Finite T
Configuration-interaction	$\Psi = \sum$ Slater det	
Self-consistent mean field Hartree-Fock-(Bogoliubov/ Bogoliubov-de Gennes)	$\delta \langle \Psi H \Psi \rangle = 0$ $\Psi =$ Slater det	$\delta F[D] = 0$ $D = e^{\text{one-body}}$
Density functional theory	$\delta E[\rho] = 0$ $\rho =$ one-body density	$\delta F[\rho] = 0$
Quantum Monte Carlo	$e^{-\tau H} \Psi_0 \rangle$ $\tau \rightarrow \infty$	$\frac{\text{Tr}(H e^{-\beta H})}{\text{Tr} e^{-\beta H}}$
Coupled cluster	$\Psi = e^S \text{Slater det} \rangle$ $S = \sum ph + \sum 2p2h + \dots$	

Self-consistent mean-field (SCMF) theories

A. Black-Schaffer, C. Horowitz, L. Robledo

Optimal independent-particle description in the presence of interactions.

- New physics is revealed by breaking symmetries.

Correlation effects beyond SCMF can be introduced in several ways:

- Restoration of broken symmetries by projection methods, e.g., angular momentum (C. Yannouleas, Y. Sun), isospin (W. Satula).
- Generator coordinate method: collective states are described as a superposition of mean-field states.
- Multi quasi-particle excitations.

Density functional theory (DFT)

D. Abergel, A. Bulgac, J. Carlson, W. Satula

- Exact functional is usually unknown and is based on approximations and/or conjectures.
- Depends on a number of parameters but is universal and global.

DFT for the unitary Fermi gas: scale invariance imposes strict constraints on possible terms in the energy density functional (unlike nuclei, where the number of terms is large).

DFT agrees with ab initio QMC calculations (J. Carlson)

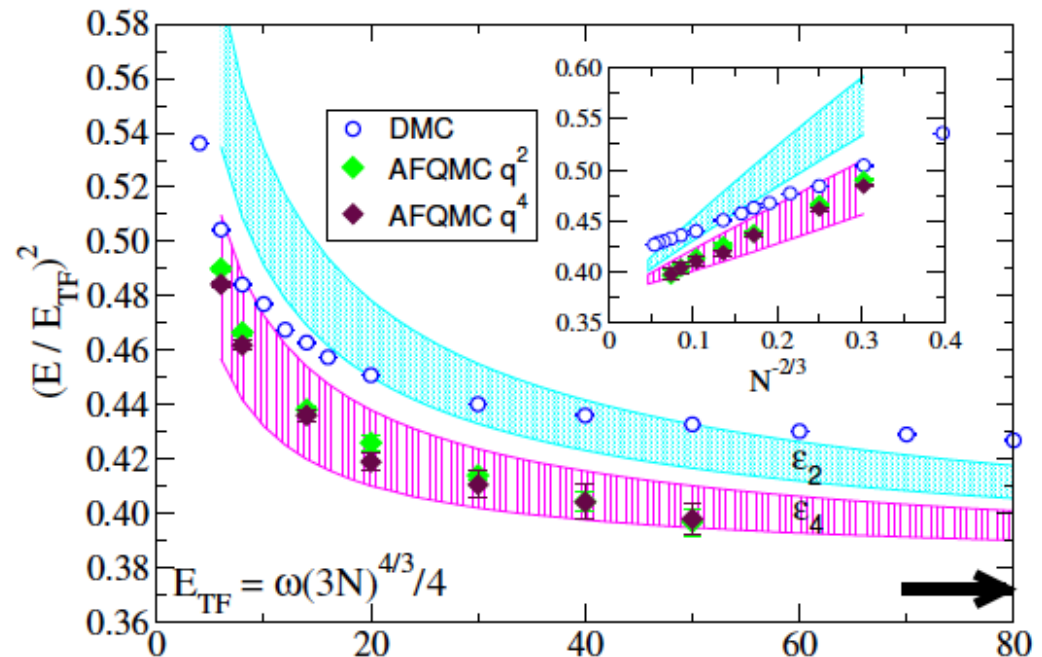

Time-dependent density functional theory (TDDFT)

- Describes real-time dynamics of many-particle systems in terms of DFT.

DFT extended to fermionic superfluids in the local density approximation (SLDA) (A. Bulgac).

- Most previous models of superfluids were phenomenological and classical (e.g., Landau, Tisza's two-fluid hydrodynamics).

Solving a large number $\sim 10^4 - 10^6$ of coupled partial differential equations on the lattice.

Example: collision of fermionic clouds

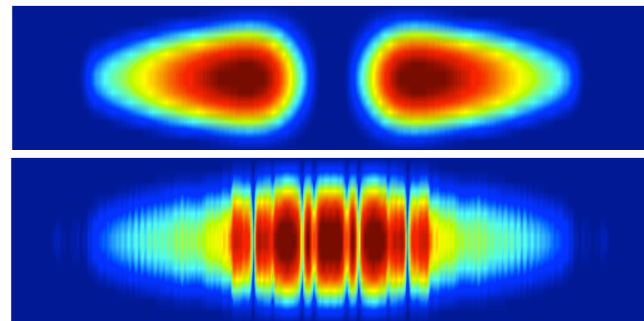

Quantum Monte Carlo (QMC) methods

J. Carlson, J. Drut, C. Gilbreth, L. Pollet, M. Wallin, S. Zhang

- Auxiliary-field Monte Carlo (AFMC)
- Diffusion Monte Carlo (DMC)
- Variational Monte Carlo (VMC)
- ...

QMC in cold atoms

Challenge problem at the 10th many-body conference (G.F. Bertsch, 1999):

What is the ground-state of a system composed of spin-1/2 fermions interacting via zero range, infinite scattering-length interaction ?

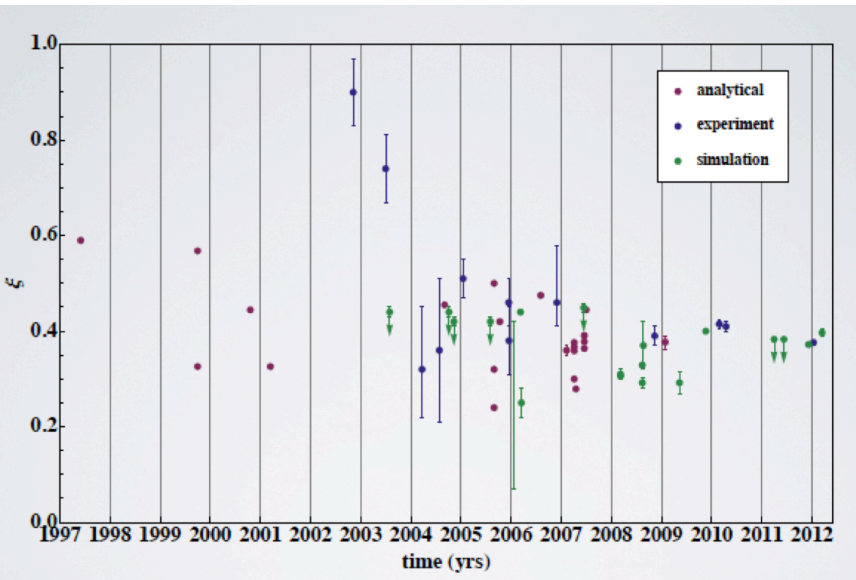

--> Unitary Fermi gas

$$E = \xi E_F \quad \xi = \text{Bertsch's parameter}$$

Theory: $\xi = 0.372 \pm 0.005$
using AFMC (Carlson et al, 2011)

Experiment: $\xi = 0.376 \pm 0.004$
(Ku et al, 2012)

AFMC in quantum chemistry

Comparable or better accuracy than the best approaches (e.g., coupled cluster), but with a better scaling (S. Zhang).

Constrained AFMC (to avoid the sign problem), and then release the constraints to improve the results.

Binding energy vs distance
between atoms

Cr₂ molecule

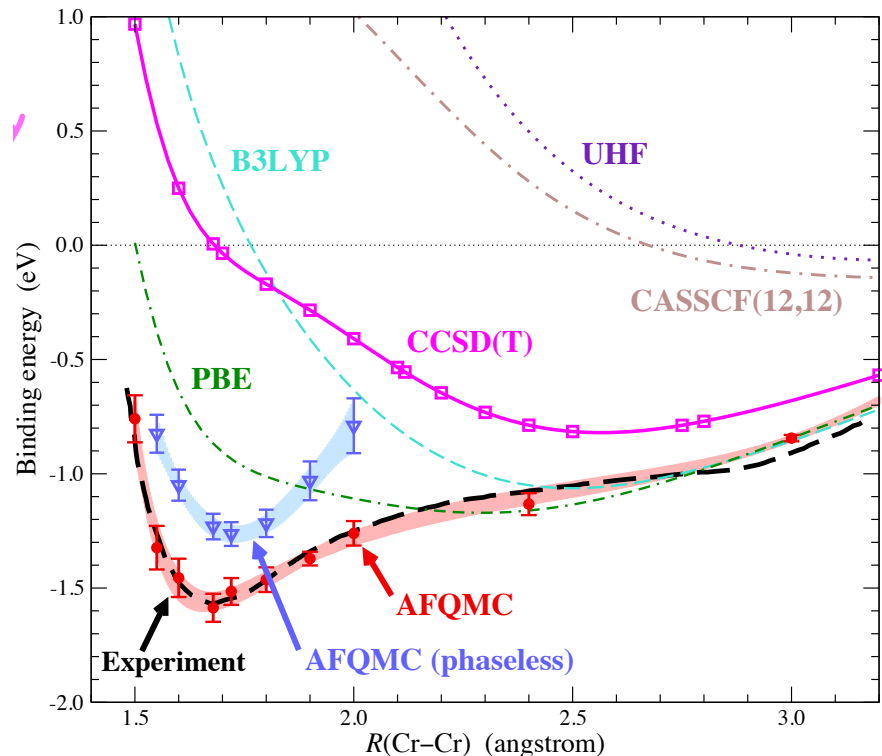

Purwanto, SZ, Krakauer, in prep, '14 (Preliminary)

AFMC in nuclei

- Derive model-independent signatures of deformation (a mean-field concept) in a rotationally invariant framework (e.g., spherical shell model).

Y.A., C. Gilbreth, G.F. Bertsch (arXiv:1408.0081)

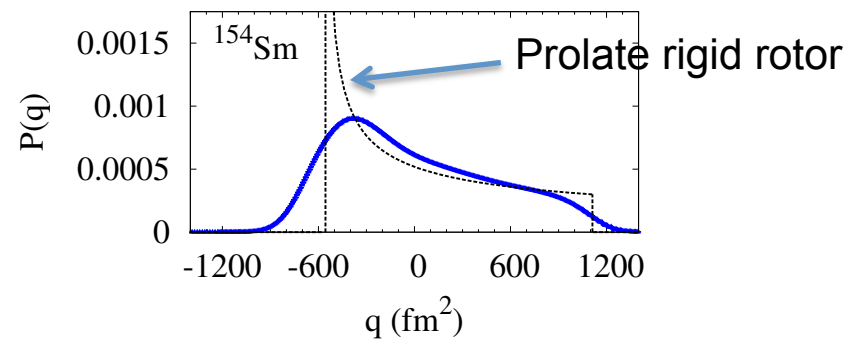
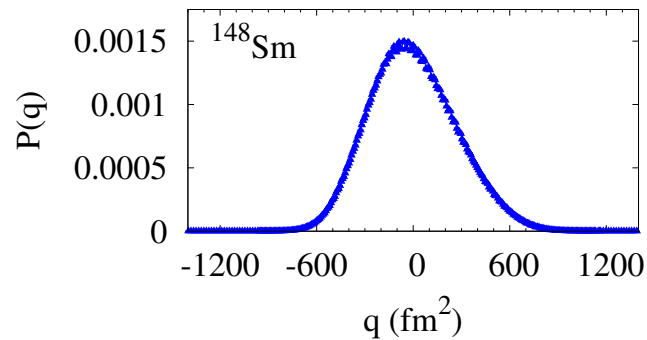

Lab-frame distributions of the axial quadrupole operator Q_{20} ($[H, Q_{20}] \neq 0$)

Lattice QMC in quantum information

Use QMC to calculate entanglement entropy in strongly correlated fermionic systems (J. Drut)

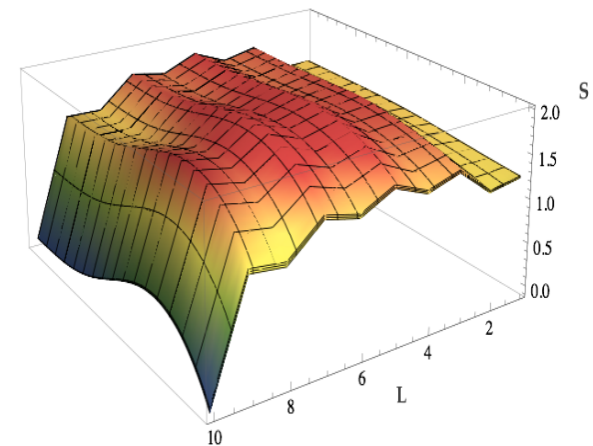

Coupled-cluster method (CCM)

R. Bishop, T. Duguet, N. Michel, T. Papenbrock

CCM in condensed matter

Used high-order CCM to construct accurate quantum phase diagrams of frustrated magnetic quantum systems (R. Bishop).

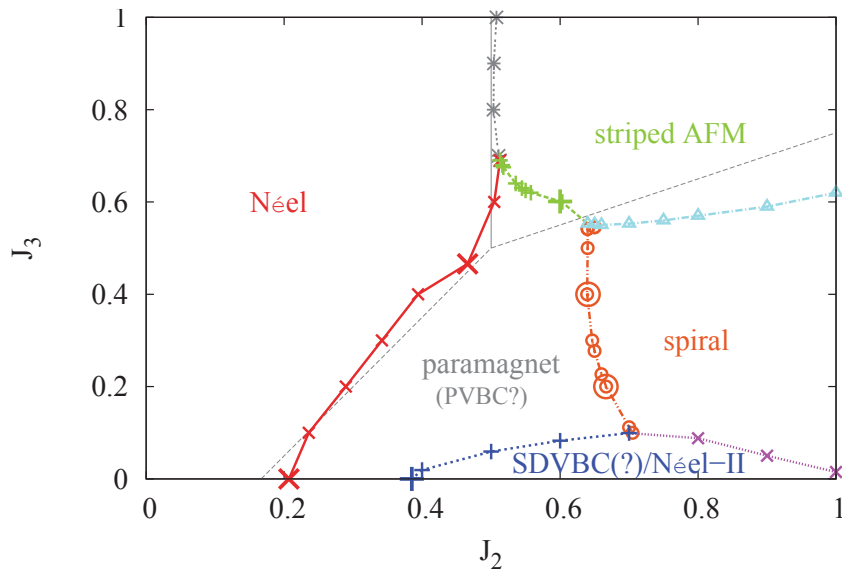

Quantum phase diagram

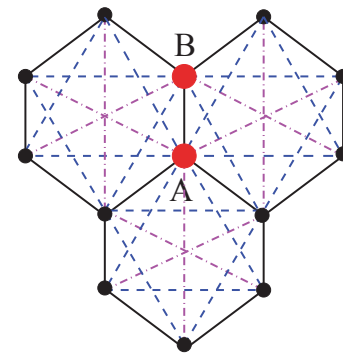

J_1 - J_2 - J_3 model on a honeycomb lattice

CCM in nuclei

Application to calcium isotopes using interaction from chiral effective field theory (T. Papenbrock).

Hagen et al., PRL 109, 032502 (2012)

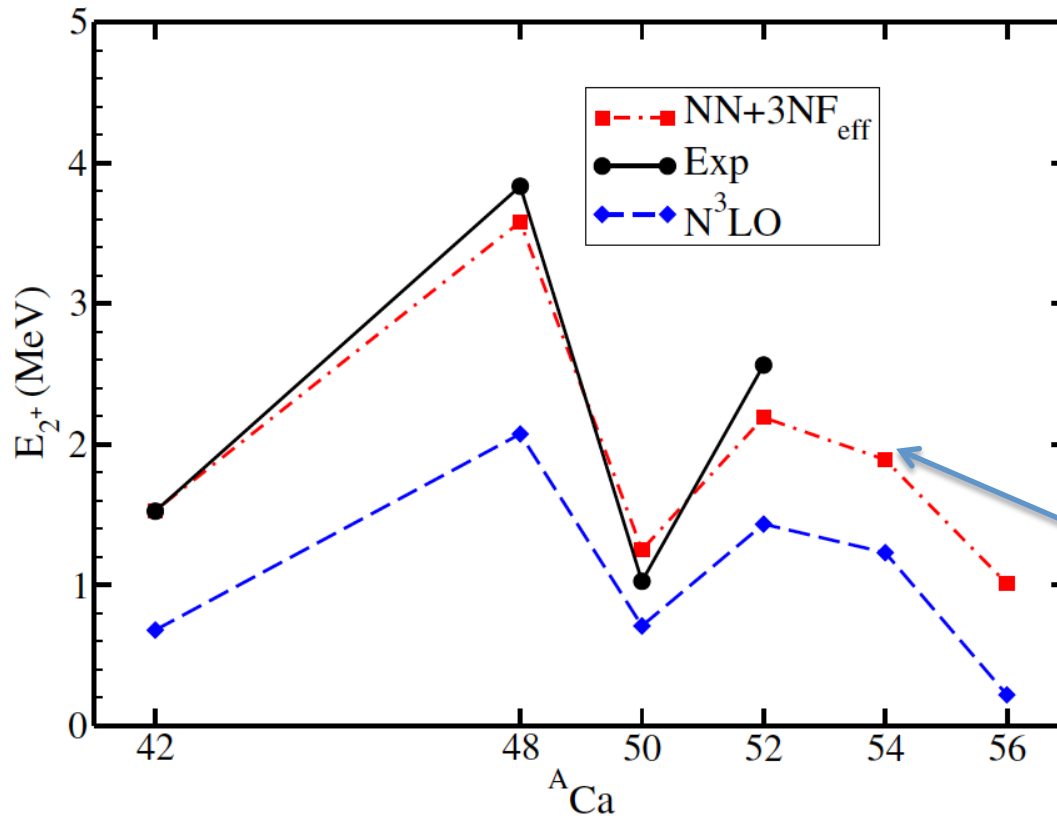

RIKEN exp. [Steppenbeck et al., Nature 502, 207 (2013)].

Shell structure of ^{52,54}Ca

Large-scale configuration-interaction approach

M. Horoi, P. Maris, N. Michel, T. Misuzaki, D. Pfannkuche, Y. Sun, Y. Suzuki, F. Xu

- Exact diagonalization in large model spaces: it is now possible to diagonalize matrices of dimension $\sim 10^{10}$ -- limited to small systems (e.g., light nuclei).
- Optimize the basis by using deformed basis and then project on good angular momentum to restore the spherical symmetry (Y. Sun).

Multi quasi-particle
Spectrum in ^{176}Hf

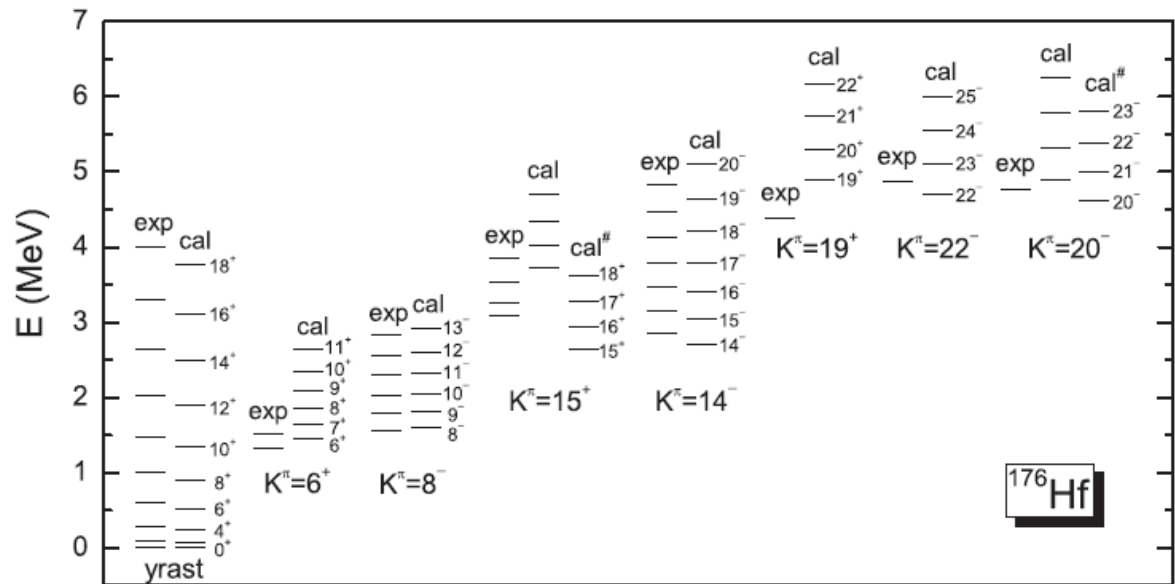
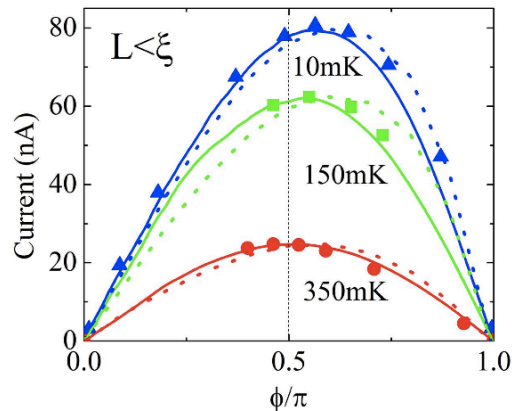

FIG. 3. Comparison of the calculated yrast, 2-qp, 4-qp, and 6-qp bands for ^{176}Hf with available experimental data taken from [40].

Pairing correlations and superconductivity

A. Black-Schaffer, M. Guidry, N. Sandulescu, Y. Zhao

Non-uniform superconducting states using Bogoliubov-de Gennes: SNS graphene Josephson junctions (A. Black-Schaffer).



- Experiment (quasi-ballistic limit)
- - - Non-self-consistent D-BdG result
- Self-consistent results

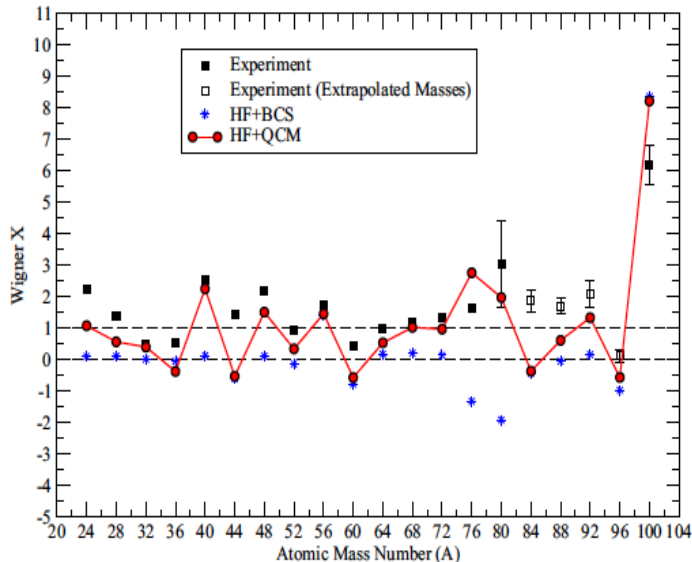

Isovector pairing and Wigner energy in the quartet formalism (N. Sandulescu)

$$E(N, Z) = E(N = Z) + \frac{T_z(T_z + X)}{2\Theta}$$

Integrable models

Integrable models (e.g., Richardson-Gaudin models) can be solved in very large many-body model spaces ([S. de Baerdemacker, J. Dukelsky](#)).

- Solvable models are used in both condensed matter and nuclear many-body systems to validate many-body methods.

- Correlated Richardson-Gaudin states used as a basis for configuration-interaction calculations.

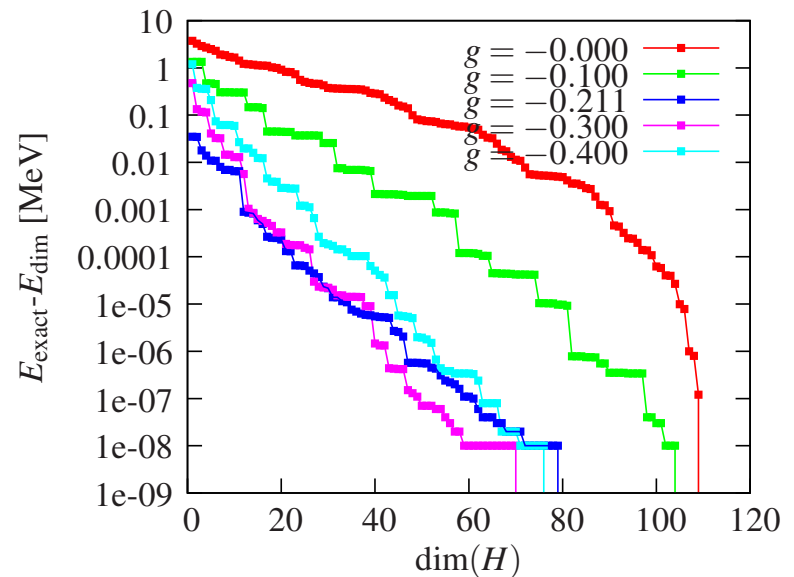

Density matrix renormalization group (DMRG) and quantum tensor networks

F. Verstraete, O. Legeza

DMRG is a powerful method in quasi 1D systems but difficult to generalize to higher dimensions.

Quantum tensor networks provide insight to DMRG and generalize it to problems in higher dimensions – can find new phases (e.g., topological).

Applications in quantum chemistry (up to 50 electrons in 50 orbitals).

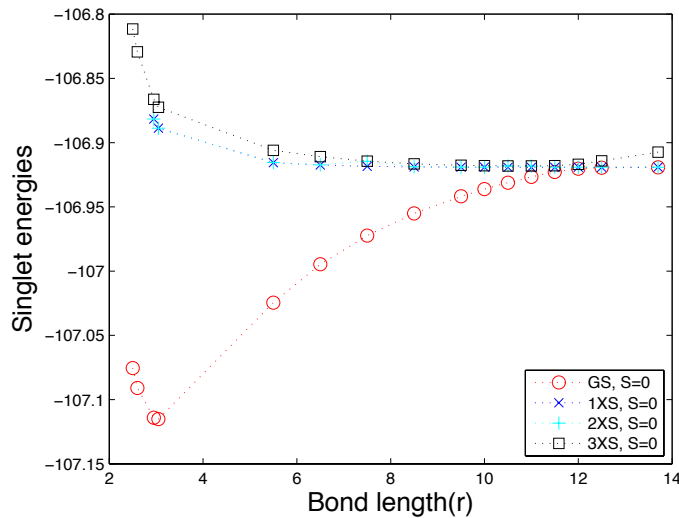

LiF molecule (O. Legeza)

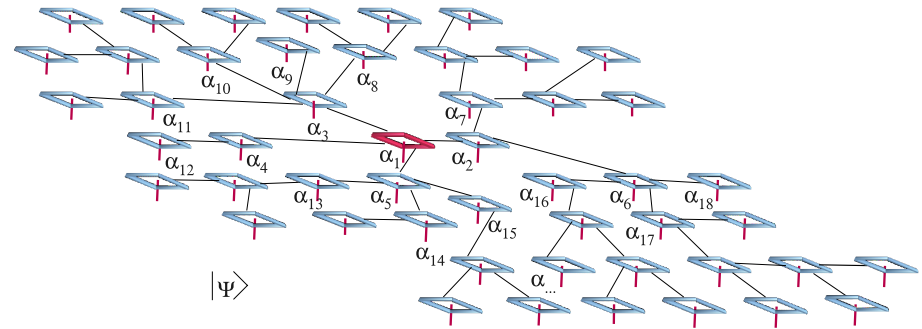

Tensor network

Some outstanding problems

- Dynamical mean-field theory (DMFT) has many applications in condensed matter theory and quantum chemistry. Is it useful for nuclear physics ?
- Finite-temperature DFT for nuclei and cold atoms ?

Cold atoms: is there an SLDA that can describe the pseudogap phase ?

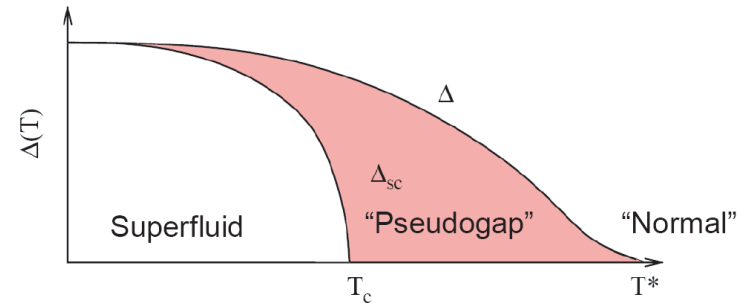

- A universal DFT that works across the nuclear chart ?
- Excited states in QMC ?

Example: find the lowest state for each good quantum number by projection.

- Response functions in QMC are calculated in imaginary time.

No good method to carry out the analytic continuation to real time.

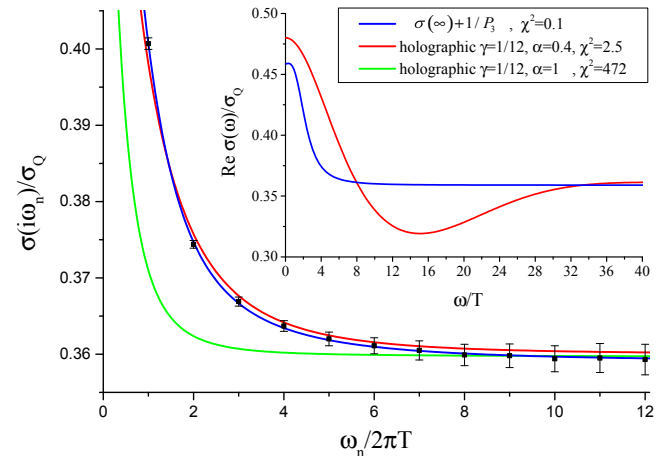

Optical conductivity (L. Pollet)
 Help from AdS/CFT correspondence ?

- Implementation of CCM in open-shell nuclei might be too time-consuming.
- CCM for excited nuclear states: 4p-4h are currently beyond reach.
- DMRG was used in the nuclear shell model with partial success. (J. Dukelsky, T. Papenbrock, S. Pittel, J. Rotureau, N. Sandulescu...).

Are tensor network methods useful for nuclei ?

- Relate seemingly different methods that complement each other.

Recent example: DFT parameters for cold atoms determined by ab initio QMC calculations.

- Energy density functionals are often constructed based on Hamiltonian models.

How to map an energy density functional on Hamiltonian models ?

- Several of the methods include uncontrolled approximations that make the estimation of systematic errors difficult.
- Extrapolations are often necessary but might not be reliable without a theoretical guidance.

It is useful to have simple models that capture the main physics of the problem and guide the more advanced and accurate computations.

“The purpose of computing is insight, not numbers”

(Richard Hamming, 1962)

“According to Einstein’s theory, if we move the computer real fast, we can go back in time and recover the files you accidentally deleted.”



Thanks the organizers for a wonderful conference !