



FACULTAD DE FÍSICA
PONTIFICIA UNIVERSIDAD CATÓLICA DE CHILE

Study of magnetic reconnection in laboratory plasma jets

Josefina Muñoz, Luisa Izquierdo, Felipe Veloso

josefina.muoz@uc.cl

Where I am from

Santiago, Chile



Pontificia Universidad Católica de Chile



Experimental plasmas at PUC

Cold plasmas

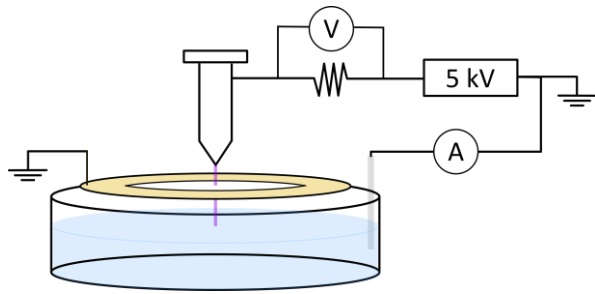

Laser produced plasma

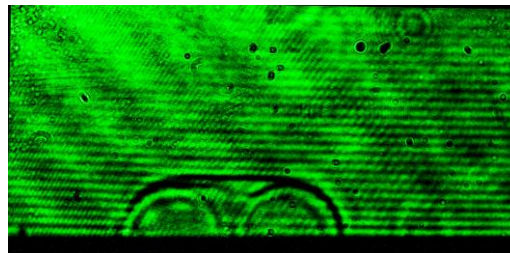
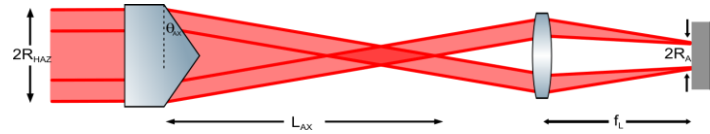

Pulsed-power generators

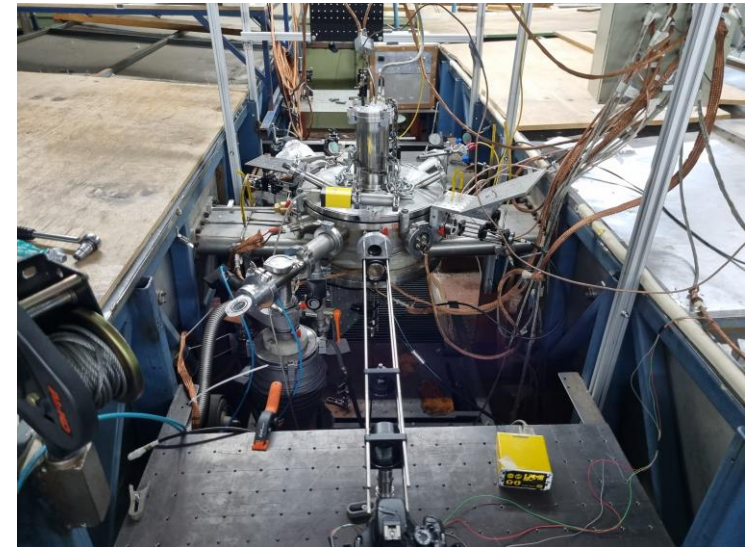
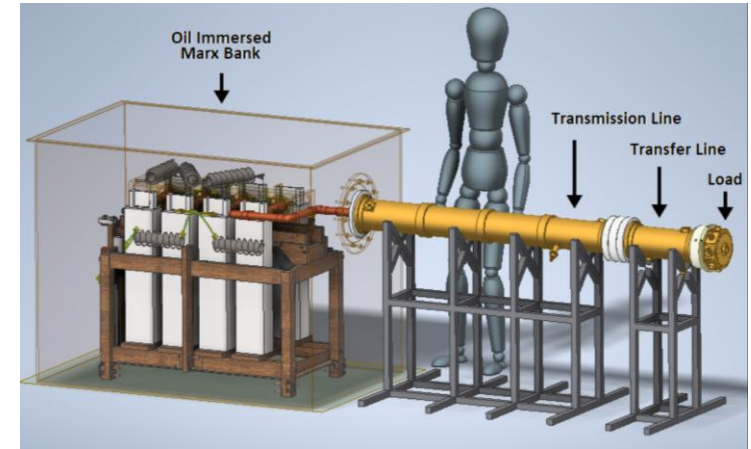

Motivation

- Laboratory HED experiments provide a platform where we can study the equations of radiation hydrodynamics and MHD in regimes relevant to astrophysical flows, implementing experimental diagnostics obtaining results that are reproducible.
- Pulsed-power-driven conical wire arrays are an attractive platform for laboratory astrophysics.

Conical wire-arrays

- When a fast current pulse is driven through a conical arrangement of thin metallic wires, the wires' surface converts to plasma, and the resulting ablation flows are accelerated and redirected by the global Lorentz force.
- For suitable geometries, the streams converge towards the array axis and form a tightly collimated supersonic jet above the anode.

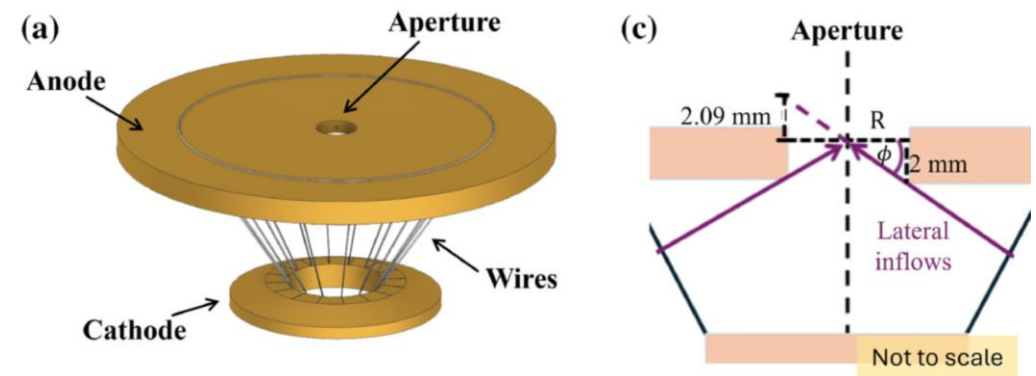
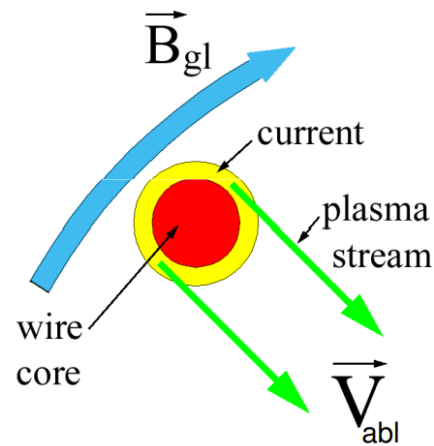

L. Izquierdo et. al., Phys. Rev. E, 10.1103/pvcm-kgvw (2026)

Astrophysical jets

- Collimated outflows are observed over a large range of scales and energies, from protoestellar jets and Herbig-Haro objects to microquasars.
- These have in common that are narrow, collimated beams emerging from an accreting source and interactions regions and bow shocks due to the interaction with the medium.



Hubble telescope image of Herbig-Haro object HH 110

Interactions

- A long-standing challenge is to understand the structure of the interaction region where a supersonic, often radiatively cooled jet encounters the ambient plasma. Astrophysical observations reveal bow shocks, and evidence of multiple type of shocks coexisting in the same system.
- By achieving adimensional parameters closely enough so that the laboratory plasma flows evolve in an analogous dynamical regime to collimated jets, they can serve as “scaled analogues” to astrophysical dynamics, in order to study these phenomena.

Llampüdkeñ

- Marx-type pulsed-power generator located at the Pontificia Universidad Católica de Chile
- 2 Marx capacitor banks + spark gaps
- Current pulses: ~ 450 kA
- Characteristic rise time: ~ 300 ns
- Upgrade: 1 MA

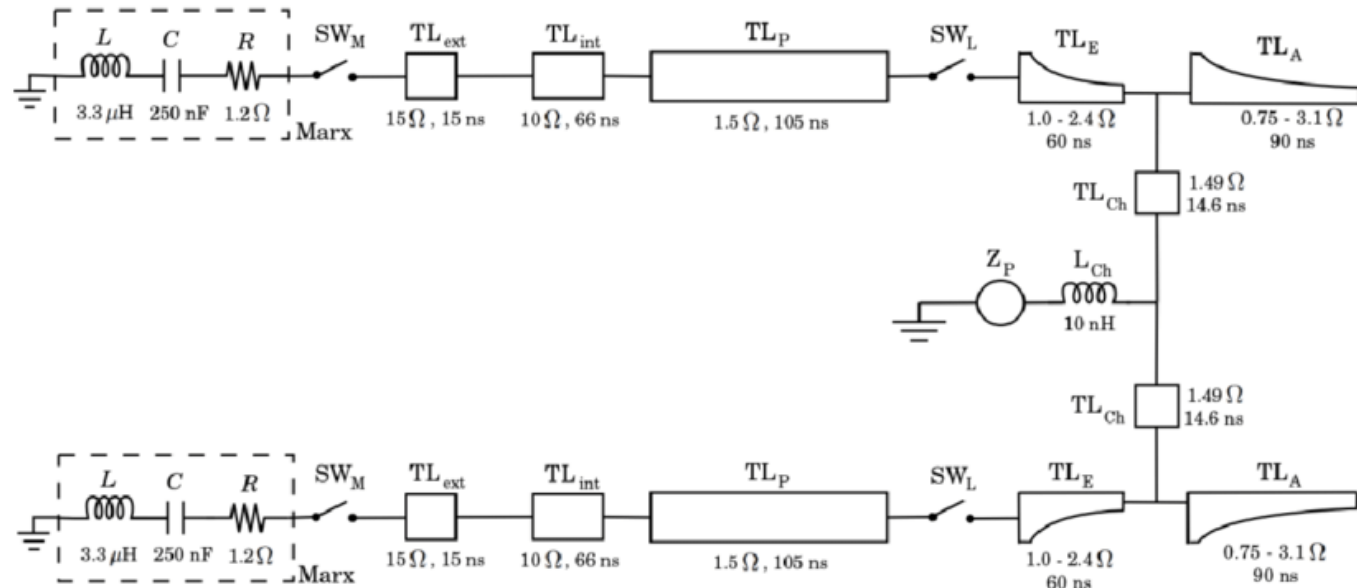
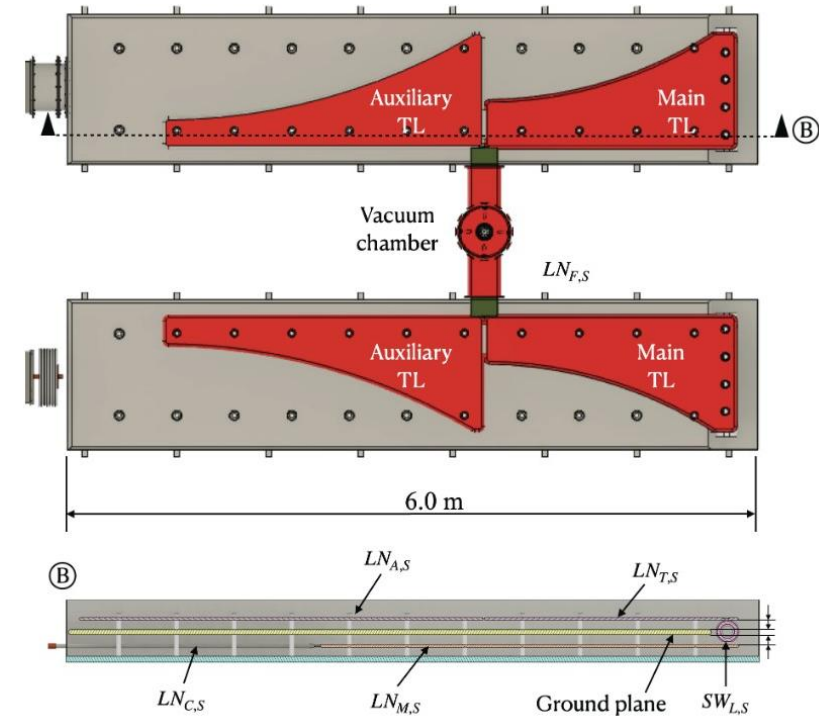

Plasma diagnostics

- Thomson scattering
- Spectroscopy
- Interferometry/Moiré-schlieren
- B-dots

$$\bullet T_e, T_i, n_e, v_z, Z^*, B$$

scientific reports

OPEN **Bayesian inference of plasma parameters from collective Thomson scattering technique on a gas-puff near stagnation**

M. Escalona¹, J. C. Valenzuela¹, G. Avaria², F. Veloso¹ & E. S. Wyndham¹

Check for updates

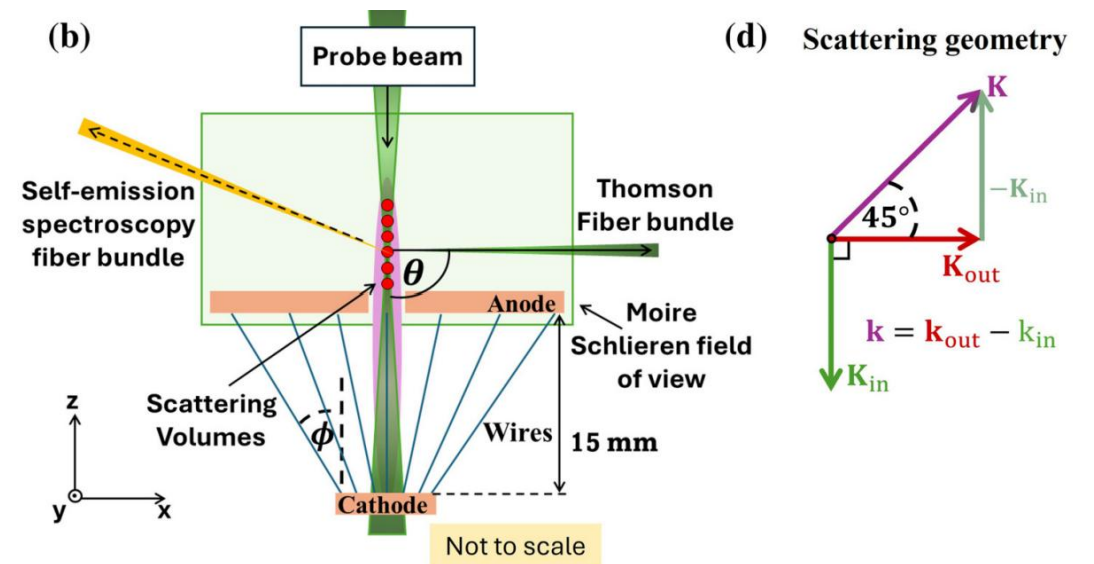

L. Izquierdo et. al., Phys. Rev. E, 10.1103/pvcm-kgvw (2026)

Lampüdken

- Provide conditions necessary to ablate, accelerate and compress matter in a controlled laboratory

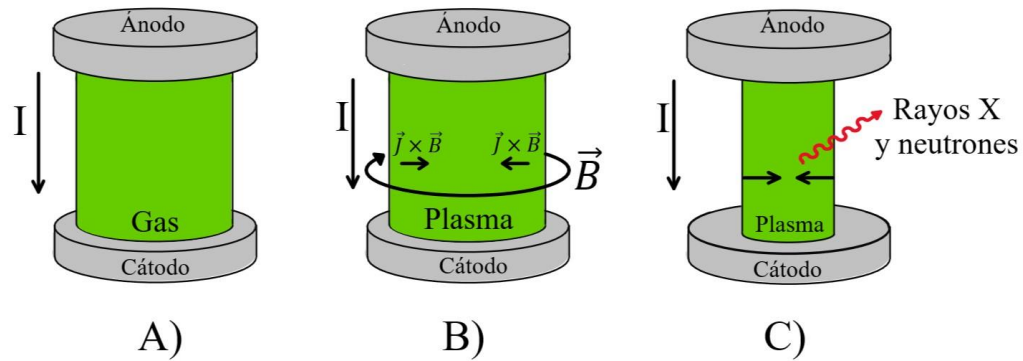

P. Phillips

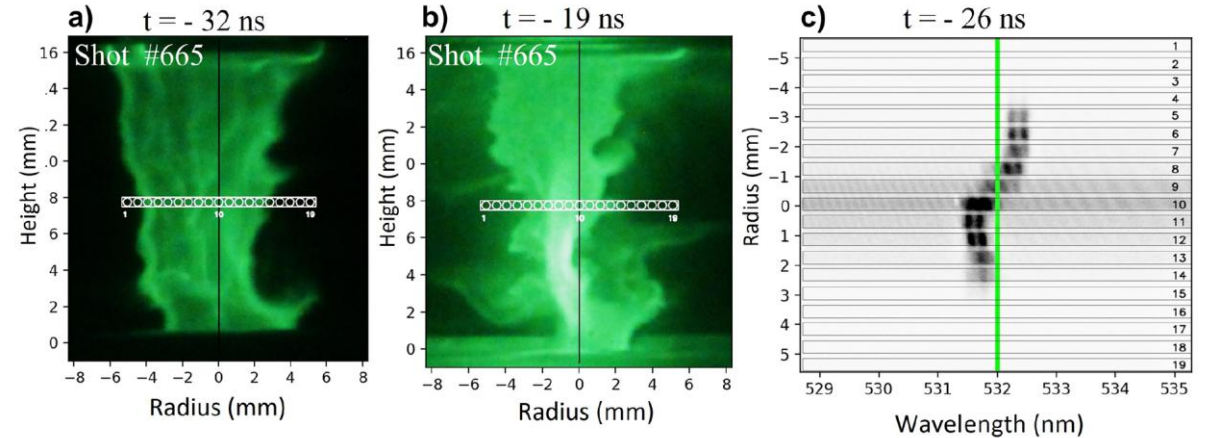

M. Escalona et. al., Scientific Reports. 10.1038/s41598-023-40014-x (2023)

Lampüdkeñ

- Provide consitions necessary to ablate, accelerate and compress matter in a controlled laboratory

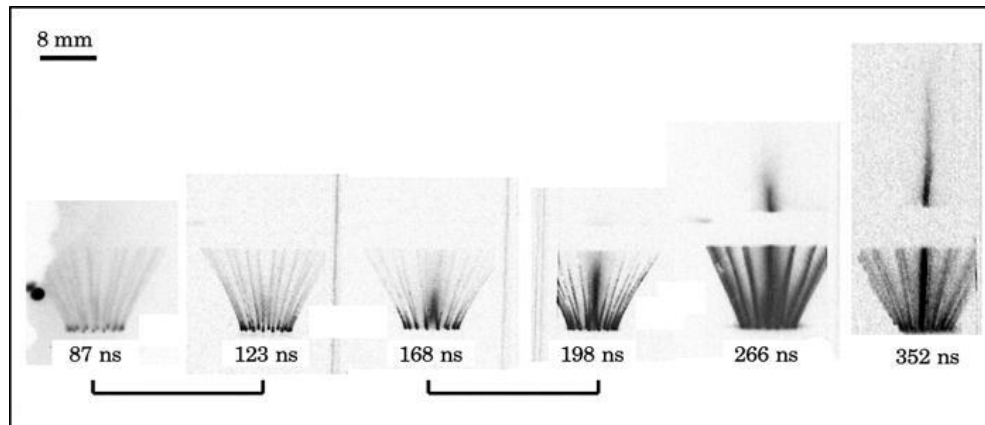

G. Muñoz et. al., Phys. Plasmas, 10.1063/1.5045215 (2018)

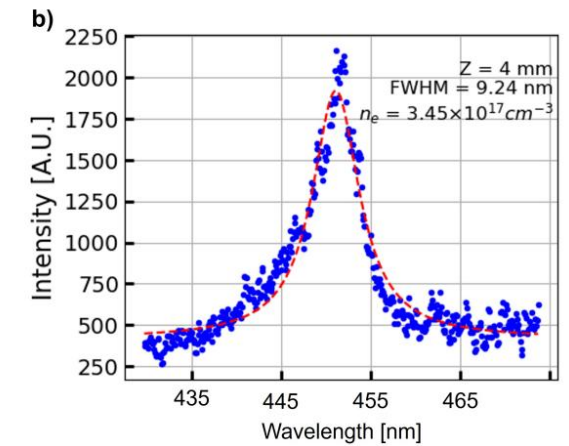
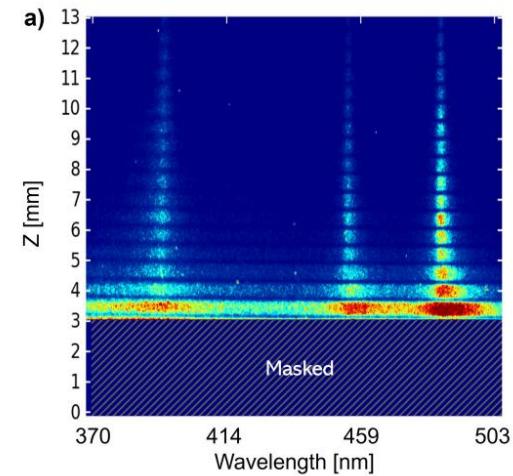

L. Izquierdo et. al., Phys. Rev. E, 10.1103/pvcm-kgvw (2026)

Reversal jets

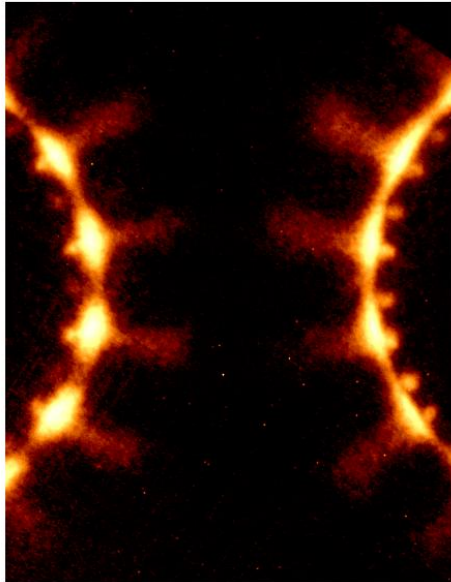

Ultra-high speed imaging of the self-emission from a magnetic reconnection experiment, showing the development of plasmoids within the reconnection layer. From <https://puffin.ece.cornell.edu/reconnection/>

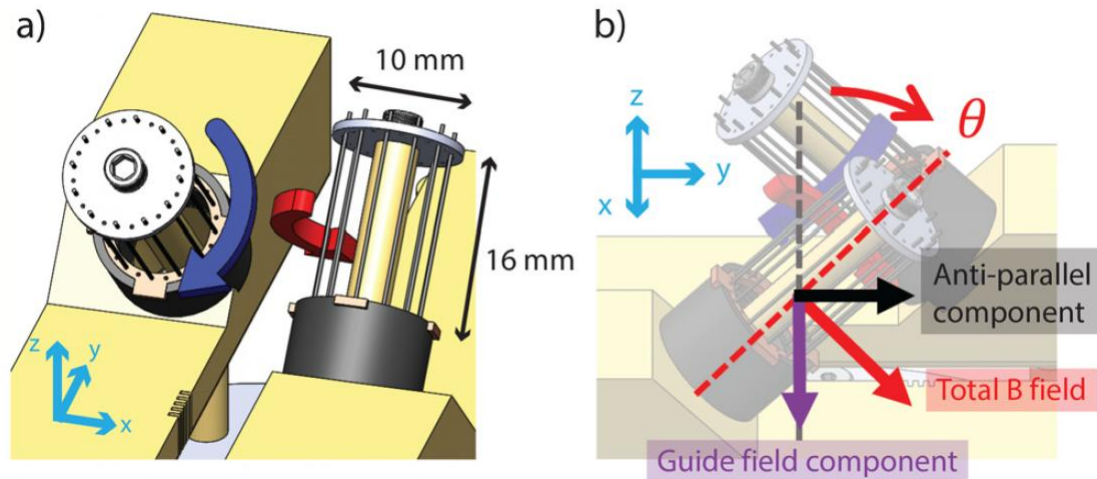

T. W. O. Varnish et. al., Phys. Plasmas, 10.1063/5.0251581 (2025)

The plan?

- Plasma jets driven by pulsed-power conical-wire arrays interactions:
 - Jet-Jet
 - Jet-obstacle
 - Jets with a guide field
 - Reversal jets-LPP
- Searching for different experimental configuration in order to study magnetic reconnection
- Searching for approaches relevant in astrophysical plasmas